Sample Exam

ISTQB[®] Foundation Level

2011 Syllabus

Version 2.9

International Software Testing Qualifications Board



Release Date: December 16th, 2017.

Copyright © 2017 International Software Testing Qualifications Board (hereinafter called ISTQB™). All rights reserved.

The authors transfer the copyright to the International Software Testing Qualifications Board (hereinafter called ISTQB™). The authors (as current copyright holders) and ISTQB™ (as the future copyright holder) have agreed to the following conditions of use:

1) Any ISTQB™ Member Board may translate this document.

Exam Working Party: 2010 – 2017

Table Of Contents

Table Of Contents	3
0. Introduction	4
0.1 Purpose of this document	4
0.2 Instructions.....	4
0.3 General Information on the sample exam paper:	4
1. Questions “Fundamentals”	5
2. Questions “Testing throughout the software life-cycle”	8
3. Questions “Static techniques”	10
4. Questions “Test design techniques”	12
5. Questions “Test management”	20
6. Questions “Test tools”	25

0. Introduction

0.1 Purpose of this document

This document contains a full sample exam following the rules described in the ISTQB Foundation Level Exam Structure and Rules document.

The sample questions, answer sets and associated justifications in this document have been created by a team of subject matter experts and experienced question writers with the aim of assisting ISTQB™ Member Boards and Exam Boards in their question writing activities as well as people planning to take the ISTQB Foundation Level examination.

These questions cannot be used as-is in any official examination, but they should serve as guidance for question writers. Given the wide variety of formats and subjects, these sample questions should offer many ideas for the individual Member Boards on how to create good questions and appropriate answer sets for their examinations. Furthermore training providers can use these questions as part of their training to prepare participants for the examination.

0.2 Instructions

The question and answer sets are organized in the following way:

- Learning Objective and K-level
- Question - including any scenario followed by the question stem
- Answer Set
- TRUE answer – including justification of the answers (The TRUE answer and justifications are contained in a separate document.)

0.3 General Information on the sample exam paper:

Number of questions: 40

Standard Duration of the examination: 60 minutes

Total number of marks possible: 40

Pass mark: 26 (or more)

1. Questions “Fundamentals”

Question 1	LO-1.3.1	K2
------------	----------	----

Which of the following statements BEST describes one of the seven key principles of software testing?

Answer Set:

- a) By using automated testing it is possible to test everything.
- b) With sufficient effort and tool support, exhaustive testing is feasible for all software.
- c) It is normally impossible to test all input/output combinations for a software system.
- d) The purpose of testing is to demonstrate the absence of defects.

Question 2	LO-1.2.1	K1
------------	----------	----

Which of the following statements is the MOST valid goal for a test team?

Answer Set:

- a) To determine whether enough component tests were executed within system testing.
- b) To detect as many failures as possible so that defects can be identified and corrected.
- c) To prove that all possible defects are identified.
- d) To prove that any remaining defects will not cause any failures.

Question 3	LO-1.4.1	K1
------------	----------	----

Which of these tasks would you expect to be performed during the Test Analysis and Design phase of the Fundamental Test Process?

Answer Set:

- a) Defining test objectives
- b) Reviewing the test basis
- c) Creating test suites from test procedures
- d) Analyzing lessons learned for process improvement

Question 4	LO-1.1.5	K2
------------	----------	----

Below is a list of problems that can be observed during testing or in production. Which one of these problems is a failure?

Answer Set:

- a) The product crashed when the user selected an option in a dialog box.
- b) One source code file included in the build has the FALSE version.
- c) The computation algorithm used FALSE input variables.
- d) The developer misinterpreted the requirement for the algorithm.

Question 5	LO-1.5.1	K1
------------	----------	----

Which of the following attitudes, qualifications or actions would lead to problems (or conflict) within mixed teams of testers and developers, when observed in reviews and tests?

Answer Set:

- a) Testers and developers are curious and focused on finding defects.
- b) Testers and developers are sufficiently qualified to find failures and defects.
- c) Testers and developers communicate defects as criticism of people, not as criticism of the software product.
- d) Testers expect that there might be defects in the software product which the developers have not found and fixed.

Question 6	LO-1.2.2	K2
------------	----------	----

Which of the following statements are TRUE?

- I. Software testing may be required to meet legal or contractual requirements.
- II. Software testing is mainly needed to improve the quality of the product.
- III. Rigorous testing and fixing of found defects could help reduce the risk of problems occurring in an operational environment.
- IV. Rigorous testing is sometimes used to prove that all failures have been found.

Answer Set:

- a) I, II and III are true; IV is false
- b) I is true; II, III, and IV are false
- c) I and III are true; II and IV are false
- d) III and IV are true; I and II are false

Question 7	LO-1.2.3	K2
------------	----------	----

Which of the following statements correctly describes the difference between testing and debugging?

Answer Set:

- a) Testing identifies the source of defects; debugging analyzes the faults and proposes prevention activities.
- b) Dynamic testing shows failures caused by defects; debugging finds, analyzes, and removes the causes of failures in the software.
- c) Testing removes faults; debugging identifies the causes of failures.
- d) Dynamic testing prevents the causes of failures; debugging removes the failures.

2. Questions “Testing throughout the software life-cycle”

Question 8	LO-2.3.3	K1
------------	----------	----

Which of the following statements BEST describes non-functional testing?

Answer Set:

- a) Non-functional testing is the process of testing an integrated system to verify that it meets specified requirements.
- b) Non-functional testing is the process of testing to determine system compliance with coding standards.
- c) Non-functional testing is testing without reference to the internal structure of a system.
- d) Non-functional testing is testing system characteristics, such as usability, reliability, or maintainability.

Question 9	LO-2.1.x	K1
------------	----------	----

When working with software development models, what is it important to do?

Answer Set:

- a) If needed, adapt the models to project and product characteristics.
- b) Choose the waterfall model, because it is the most proven model.
- c) Start with the V-model, and then move to either the iterative or the incremental model.
- d) Change the organization to fit the model, not vice versa.

Question 10	LO-2.1.3	K1
-------------	----------	----

Which of the following is a characteristic of good testing and applies to any software development life cycle model?

Answer Set:

- a) Acceptance testing is always the final test level to be applied.
- b) All test levels are planned and completed for each developed feature.
- c) Testers are first involved when first piece of code can be executed.
- d) For every development activity there is a corresponding testing activity.

Question 11	LO-2.4.1	K1
-------------	----------	----

Which of the following is an example of maintenance testing?

Answer Set:

- a) To test corrected defects during development of a new system.
- b) To test enhancements to an existing operational system.
- c) To handle complaints about system quality during user acceptance testing.
- d) To integrate functions during the development of a new system.

Question 12	LO-2.3.5	K2
-------------	----------	----

Which of the following statements are TRUE?

- I. Regression testing and confirmation testing are the same.
- II. Regression testing shows that all defects have been resolved.
- III. Regression testing is a good candidate for test automation.
- IV. Regression testing is performed to uncover defects as a result of changes in the software.
- V. Regression testing should not be performed during integration testing.

Answer Set:

- a) IV is true; I, II, III and V are false
- b) III is true; I, II, IV and V are false
- c) III and IV are true; I, II and V are false
- d) I, III and IV are true; II and V are false

Question 13	LO-2.2.1	K2
-------------	----------	----

Which of the following statements comparing component testing and system testing is TRUE?

Answer Set:

- a) Component testing verifies the functionality of software modules, program objects, and classes that are separately testable, whereas system testing verifies interfaces between components and interactions between different parts of the system.
- b) Test cases for component testing are usually derived from component specifications, design specifications, or data models, whereas test cases for system testing are usually derived from requirement specifications, functional specifications, or use cases.
- c) Component testing only focuses on functional characteristics, whereas system testing focuses on functional and non-functional characteristics.
- d) Component testing is the responsibility of the testers, whereas system testing typically is the responsibility of the users of the system.

3. Questions “Static techniques”

Question 14	LO-3.2.1	K1
-------------	----------	----

Which of the following describes the main phases of a formal review?

Answer Set:

- a) Initiation, backtracking, individual preparation, review meeting, rework, follow-up
- b) Planning, individual preparation, review meeting, rework, closure, follow-up
- c) Planning, kick off, individual preparation, review meeting, rework, follow-up
- d) Individual preparation, review meeting, rework, closure, follow-up, root cause analysis

Question 15	LO-3.2.2	K2
-------------	----------	----

Which of the review types below is the BEST option to choose for reviewing safety critical components in a software project if additionally the review must be demonstrated as a formal process based on rules and checklists?

Answer Set:

- a) Informal Review
- b) Technical Review
- c) Inspection
- d) Walkthrough

Question 16	LO-3.3.2	K1
-------------	----------	----

Which of the following statements about tool-supported static analysis is FALSE?

Answer Set:

- a) Tool-supported static analysis can be used as a preventive measure with appropriate processes in place.
- b) Tool-supported static analysis can find defects that are not easily found by dynamic testing.
- c) Tool-supported static analysis can result in cost savings by finding defects early.
- d) Tool-supported static analysis is a good way to force failures into the software.

4. Questions "Test design techniques"

Question 17

LO-4.4.4

K4

One of the test goals for your project is to have 100% decision coverage. The following three tests have been executed for the control flow graph shown below.

Test_01 covers path: A, B, D, E, G

Test_02 covers path: A, B, D, E, F, G

Test_03 covers path: A, C, F, C, F, C, F, G

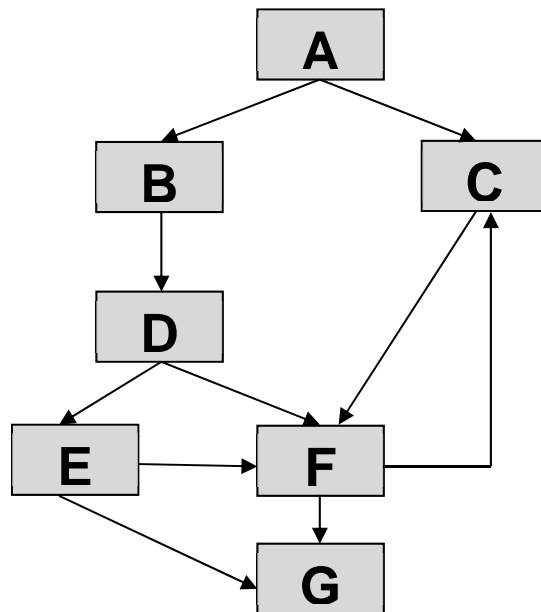

Which of the following statements related to the decision coverage goal is TRUE?

Answer Set:

- a) Decision D has not been tested completely.
- b) 100% decision coverage has been achieved.
- c) Decision E has not been tested completely.
- d) Decision F has not been tested completely.

Question 18	LO-4.2.2	K2
-------------	----------	----

A defect was found during testing:

While receiving customer data from a server the system crashed. The defect was fixed by correcting the code that checked the network availability during data transfer. The existing test cases covered 100% of all statements of the corresponding module. To verify the fix and to ensure more extensive coverage, some new tests were designed and added to the test suite and executed.

Which of the following test types should be used in this scenario?

- I. Functional testing
- II. Structural testing
- III. Re-testing
- IV. Performance testing

Answer Set:

- a) I and II are used, but not III and IV
- b) I and III are used, but not II and IV
- c) I, II and III are used, but not IV
- d) II, III and IV are used, but not I

Question 19	LO-4.3.1	K3
-------------	----------	----

Which of the following statements about the given state transition diagram and table of test cases is TRUE?

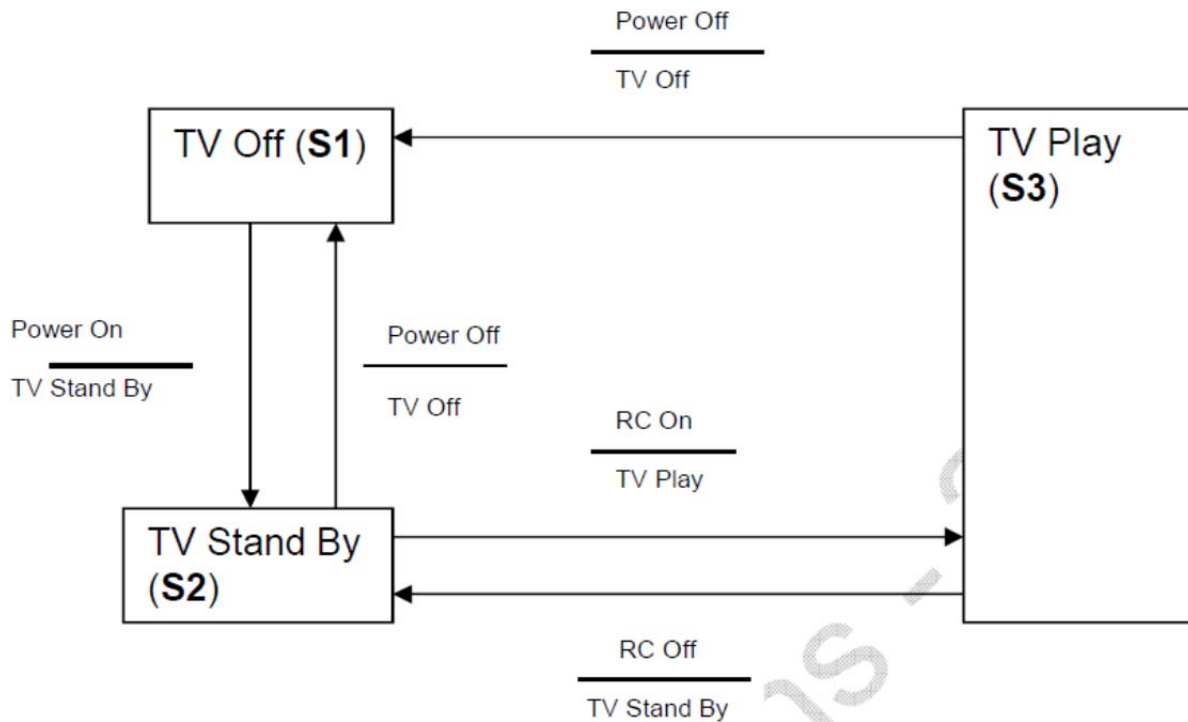

Test Case	1	2	3	4	5
Start State	S1	S2	S2	S3	S3
Input	Power On	Power Off	RC On	RC Off	Power Off
Expected Output	TV Stand By	TV Off	TV Play	TV Stand By	TV Off
Final State	S2	S1	S3	S2	S1

Answer Set:

- a) The given test cases can be used to derive both valid and invalid transitions in the state transition diagram.
- b) The given test cases represent all possible valid transitions in the state transition diagram.
- c) The given test cases represent only some of the valid transitions in the state transition diagram.
- d) The given test cases represent sequential pairs of transitions in the state transition diagram.

Question 20	LO-4.3.2	K2
-------------	----------	----

Which of the following statements for the equivalence partitioning test technique are TRUE?

Equivalence partition testing ...

- I. divides possible inputs into classes where all elements are expected to cause the same behavior.
- II. uses both valid and invalid partitions.
- III. must include at least two values from every equivalence partition.
- IV. can be used only for testing equivalence partition inputs from a Graphical User Interface.

Answer Set:

- a) I, II and IV are TRUE; III is FALSE
- b) I is TRUE; II, III and IV are FALSE
- c) II and III are TRUE; I and IV are FALSE
- d) I and II are TRUE; III and IV are FALSE

Question 21	LO-4.2.2	K1
-------------	----------	----

Which of the following options lists techniques categorized as Black Box design techniques?

Answer Set:

- a) Equivalence Partitioning, Decision Table testing, State Transition testing, and Boundary Value analysis
- b) Equivalence Partitioning, Decision Table testing, Statement coverage, Use Case Based testing
- c) Equivalence Partitioning, Decision Coverage testing, Use Case Based testing
- d) Equivalence Partitioning, Decision Coverage testing, Boundary Value analysis

Question 22	LO-4.3.1	K3
-------------	----------	----

An employee's bonus is to be calculated. It cannot be negative, but it can be calculated down to zero. The bonus is based on the length of employment.

The categories are: less than or equal to 2 years, more than 2 years but less than 5 years, 5 or more years, but less than 10 years, 10 years or longer. Depending on the length of employment, an employee will get different levels of bonus.

How many test cases are necessary, if only valid equivalence partitions are needed to test the calculation of the bonus?

Answer Set:

- a) 3
- b) 5
- c) 2
- d) 4

Question 23	LO-4.3.5	K3
-------------	----------	----

Which of the following statements about the benefits of deriving test cases from use cases are true and which are false?

- I. Deriving test cases from use cases is helpful for system and acceptance testing.
- II. Deriving test cases from use cases is helpful only for automated testing.
- III. Deriving test cases from use cases is helpful for component testing.
- IV. Deriving test cases from use cases is helpful for integration testing.

Answer Set:

- a) I and IV are true; II and III are false
- b) I is true; II, III, and IV are false
- c) II and IV are true; I and III are false
- d) I, III and IV are true; II is false

Question 24	LO-4.5.1	K2
-------------	----------	----

Which of the options below would be the BEST basis for testing using fault attacks?

Answer Set:

- a) Experience, defect and failure data; knowledge about software failures
- b) Risk identification performed at the beginning of the project
- c) Use Cases derived from business flows by domain experts
- d) Expected results from comparison with an existing system

Question 25	LO-4.5.1	K1
-------------	----------	----

You are working on a project that has poor specifications and time pressure.

Which of the following test techniques would be the most useful approach to use?

Answer Set:

- a) Use Case Testing
- b) Statement Testing
- c) Exploratory Testing
- d) Decision Testing

Question 26	LO-4.2.2	K1
-------------	----------	----

Which of the following test techniques is a white-box technique?

Answer Set:

- a) Decision Testing
- b) Boundary Value Analysis
- c) Equivalence Partitioning
- d) State Transition Testing

Question 27	LO-4.3.1	K3
-------------	----------	----

You are testing a system that calculates the greatest common divisor (GCD) of two integers (A and B) greater than zero. [K3]

calcGCD (A, B);

The following test inputs have been specified.

Test Case	A	B
1	1	1
2	INT_MAX	INT_MAX
3	1	0
4	0	1
5	INT_MAX+1	1
6	1	INT_MAX+1

where INT_MAX is the largest Integer.

Which specification-based test technique would you use for test cases 1 through 6?

Answer Set:

- a) Boundary Value Analysis
- b) State Transition Testing
- c) Use Case Testing
- d) Decision Table Testing

Question 28	LO-4.3.1	K3
-------------	----------	----

A company's employees are paid bonuses if they work more than a year in the company and achieve individually agreed targets.

The following decision table has been designed to test the system:

		T1	T2	T3	T4	T5	T6	T7	T8
Conditions									
Cond1	Employment for more than 1 year?	YES	NO	YES	NO	YES	NO	YES	NO
Cond2	Agreed target?	NO	NO	YES	YES	NO	NO	YES	YES
Cond3	Achieved target?	NO	NO	NO	NO	YES	YES	YES	YES
Action									
	Bonus payment?	NO	NO	NO	NO	NO	NO	YES	NO

Which test cases could be eliminated in the above decision table because the test case wouldn't occur in a real situation?

Answer Set:

- a) T1 and T2
- b) T3 and T4
- c) T7 and T8
- d) T5 and T6

5. Questions “Test management”

Question 29	LO-5.1.4	K1
-------------	----------	----

Which of the following BEST describes how tasks are divided between the test manager and the tester?

Answer Set:

- a) The test manager plans testing activities and chooses the standards to be followed, while the tester chooses the tools and controls to be used.
- b) The test manager plans, organizes, and controls the testing activities, while the tester specifies and executes tests.
- c) The test manager plans, monitors, and controls the testing activities, while the tester designs tests and decides about the approval of the test object.
- d) The test manager plans and organizes the testing, and specifies the test cases, while the tester prioritizes and executes the tests.

Question 30	LO-5.5.3	K1
-------------	----------	----

Which of the following can be categorized as a product risk?

Answer Set:

- a) Low quality of requirements, design, code and tests.
- b) Political problems, and delays in especially complex areas in the product.
- c) Error-prone areas, potential harm to the user, poor product characteristics.
- d) Problems in defining the right requirements, potential failure areas in the software or system.

Question 31	LO-5.2.9	K2
-------------	----------	----

Which of the following are typical exit criteria from testing?

Answer Set:

- a) Test coverage measures, reliability measures, test cost, schedule, status of defect correction and residual risks
- b) Test coverage measures, reliability measures, degree of tester independence, and product completeness
- c) Test coverage measures, reliability measures, test cost, availability of testable code, time to market, and product completeness
- d) Time to market, residual defects, tester qualification, degree of tester independence, test coverage measures and test cost

Question 32

LO-5.2.5

K3

As a Test Manager, you have the following requirements to test:

- R1 – Process Anomalies
- R2 – Synchronization
- R3 – Confirmation
- R4 – Issues
- R5 – Financial Data
- R6 – Diagram Data
- R7 – Changes to the User Profile

The notation to indicate any Requirement's logical dependencies is, for example, "R1 -> R3" meaning that R3 is dependent on R1.

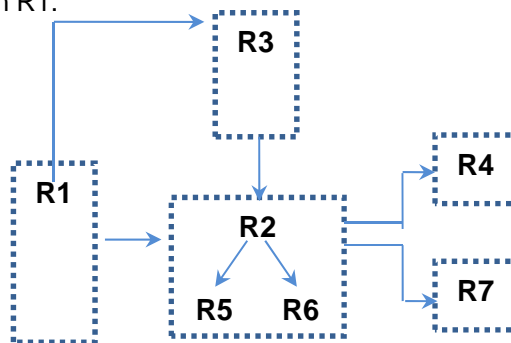

Which of the following options structures the test execution schedule according to the requirement dependencies?

Answer Set:

- a) R3 --> R2 --> R1 --> R7 --> R5 --> R6 --> R4
- b) R2 --> R5 --> R6 --> R4 --> R7 --> R1 --> R3
- c) R1 --> R3 --> R2 --> R5 --> R6 --> R4 --> R7
- d) R1 --> R2 --> R5 --> R6 --> R3 --> R4 --> R7

Question 33	LO-5.1.1	K1
-------------	----------	----

Which of the following is a possible benefit of independent testing?

Answer Set:

- a) More work gets done because testers do not disturb the developers all the time.
- b) Independent testers tend to be unbiased and find different defects than the developers.
- c) Independent testers do not need extra education and training.
- d) Independent testers reduce the bottleneck in the incident management process.

Question 34	LO-5.5.4	K1
-------------	----------	----

Which of the following is a project risk?

Answer Set:

- a) Skill and staff shortages
- b) Poor software characteristics (e.g. usability)
- c) Failure-prone software delivered
- d) Possible reliability

Question 35	LO-5.3.3	K2
-------------	----------	----

As a test manager, you are asked for a test summary report. Concerning test activities, and according to the IEEE 829 Standard, what should be the MOST important information to include in your report?

Answer Set:

- a) The number of test cases executed and their results.
- b) An overview of the major testing activities, events and the status with respect to meeting goals
- c) Overall evaluation of each development work item
- d) Training taken by members of the test team to support the test effort

Question 36	LO-5.6.2	K3
-------------	----------	----

You are a tester in a safety-critical software development project. During execution of a test, you find out that one of your test cases failed, causing you to write an incident report.

According to the IEEE Std. 829, what should you consider to be the MOST important information to include in your incident report in the context of a safety-critical development?

Answer Set:

- a) Impact, incident description, date and your name
- b) Unique ID for the report, special requirements needed and the person who caused the defect
- c) Transmitted items, your name and your feelings about the possible root cause of the defect
- d) Incident description, development environment and expected results of testing

6. Questions “Test tools”

Question 37	LO-6.3.1	K1
-------------	----------	----

From the list below, which are the recommended principles for introducing a test tool to an organization?

1. Roll out the tool to the entire organization at the same time
2. Start with a pilot project
3. Adapt and improve processes to fit the use of the tool
4. Provide training and coaching for new users
5. Let each team decide their own way of using the tool
6. Monitor that costs do not exceed initial acquisition cost
7. Gather lessons learned from all teams

Select ONE option.

Answer Set:

- a) 1, 3, 4, 5
- b) 2, 5, 6
- c) 2, 3, 4, 7
- d) 1, 6, 7

Question 38	LO-6.2.2	K1
-------------	----------	----

Which of the following BEST describes a characteristic of a keyword-driven test execution tool?

Answer Set:

- a) A table with test input data, action words, and expected results controls execution of the system under test.
- b) Tester actions are automated using a script that is rerun several times.
- c) Tester actions are automated using a script that is run with several sets of test input data.
- d) The ability to log test results, and compare them against the expected results stored in a text file.

Question 39	LO-6.3.2	K1
-------------	----------	----

Which of the following is NOT a goal of a pilot project for tool evaluation?

Answer Set:

- a) To evaluate how the tool fits with existing processes and practices.
- b) To determine use, management, storage, and maintenance of the tool and testware.
- c) To assess whether the benefits will be achieved at reasonable cost.
- d) To reduce the defect rate in the pilot project.

Question 40	LO-6.1.3	K2
-------------	----------	----

A software development and test organization would like to achieve the test efficiency improvement goals listed below.

Which would best be supported by a test management tool?

Answer Set:

- a) Enable traceability between requirements, tests, and defects (bugs)
- b) Optimize the ability of tests to identify failures
- c) Resolve defects faster
- d) Automate a selection of test cases for execution